

# OWNERS MANUAL

# REIONATOR<sup>®</sup> PRO

## Whole House Water Conditioner

With Triton Electronic Control Valve

**Activate your warranty by registering  
your product at [watertech.com](http://watertech.com) or  
call 469-521-1180.**



SCAN ME



IAPMO R&T certified to NSF/ANSI Standards 42 and 44  
for meeting or exceeding industry standards of aesthetic  
chlorine reduction and softening efficiency.

**WATER**  **TECH**<sup>™</sup>  
**FILTRATION SYSTEMS**



## DEALER CONTACT AND PRODUCT INFORMATION

Dealer Name: \_\_\_\_\_

Dealer Phone Number: \_\_\_\_\_ Installation Date: \_\_\_\_\_

Model Number: \_\_\_\_\_ Serial Number: \_\_\_\_\_

## CUSTOMER CHECKLIST

After installation, installer should make sure of the following:

- Customer has an Owner's Manual
- Customer knows how to restart system if power goes out
- Customer knows how to put the system in bypass in case of an emergency
- Customer knows what kinds of regenerant to use in brine tank
- Customer knows where to purchase regenerant salt or potassium chloride
- Customer knows how often to check regenerant salt/potassium level
- Customer knows how much salt or potassium chloride to put in brine tank
- Customer knows how to contact dealer in case of service needs
- Customer is aware that they must register their product online or by phone to activate their Reionator Pro limited lifetime warranty coverage



**Activate your warranty by registering  
your product at [watertech.com](http://watertech.com) or call  
469-521-1180.**

# MAINTENANCE

This manual is applicable to one of the following model numbers:

## ***Pro Series: RX10, RX12, RX13, RXF10***

With minimal care, your system is designed to serve you for many years. While constant attention to your system is not necessary, the following suggestions will ensure your system's performance and your convenience and satisfaction.

## **MAINTENANCE**

- Salt in the brine tank is used as a resin 'cleaner' to remove contaminants during the regeneration process. Check the salt level of the brine tank every month to make sure your system is using salt. Your Reionator Pro® will function properly whether the salt tank is near full or near empty, refill when there is about 1 bag worth of salt remaining
- Use only premium-grade regenerant salt that is designed specifically for use with water softeners and conditioners. Sodium (NaCl) salt may be used. Potassium (KCl) is recommended in most applications for superior taste, odor, aesthetic and environmental benefits.

## **SERVICE ISSUES**

- If the Triton control valve system display does not appear, check to make sure the system is plugged in and that there is power at the receptacle. If the unit does not respond with power present, contact your WaterTech Dealer.
- The manual bypass valve (which is located at the rear of the unit) is designed to isolate the unit from the plumbing for servicing or to shut off the water supply to the unit in the event of a leak at the conditioner. Consult the operating diagram on page 11 of this manual for instructions to position your bypass valve for either service or isolation.
- If you experience an extended power outage (over an hour in length), you may need to reset the time of day on the Triton control valve. The internal battery is designed to retain the time of day for up to 24 hours. There is no need to reset any other part of the program as this is kept in non-volatile, permanent memory. Consult the programming instructions on page 8 of this manual for instructions to set the electronic time clock of the Triton control valve.
- If you experience a change in water quality:
  1. First check to see if your brine tank is empty (see above). If necessary, add regenerant salt.
  2. Check to see if your system has power (see above).
  3. Check to see if the drain line has a kink that may be restricting flow during regeneration. Correct, if necessary, or contact your WaterTech Dealer.

# DO'S AND DONT'S

- **DO ALWAYS** check your state and local regulations regarding plumbing and electrical connections and placement of the system before installation.
- **DO** install the Reionator Pro® system into the existing cold water supply line before the water heater and before any cold water outlet that requires treatment.
- **DO** bypass your system in the event of a water or plumbing related emergency.
- **DO** decrease your usage of all cleaning products such as: soap, detergents, shampoo, etc. Most homes can reduce their use of these products by 50% to 75% because they work more efficiently in Reionator Pro® conditioned water.
- **DO** inspect the brine tank monthly.
- **DO** initiate a regeneration manually if high water usage is expected due to guests, heavy laundry or other reasons.
- **DO** contact your WaterTech Dealer if you have any questions about the operation of your system or water quality issues.
- **DO** enjoy all the benefits of your Reionator Pro® conditioned water!
- **DO NOT** hang or stack items on your equipment. This may cause an equipment imbalance or put a strain on plumbing and electrical connections.
- **DO NOT** disconnect or remove any part of the plumbing or electrical cord.
- **DO NOT** attempt to reprogram your system (except for the time clock setting). Your system has been factory or field programmed specifically for your application.
- **DO NOT** overfill the brine tank with salt. Approximately 6 inches below the rim is the maximum recommended fill.
- **DO NOT** allow your Reionator Pro® and attached plumbing to be exposed to extreme temperatures (below 40° F or above 110° F).
- **DO NOT** use with water that is microbiologically unsafe or of unknown quality without adequate disinfection before or after the system.

# PARTS LIST - RX

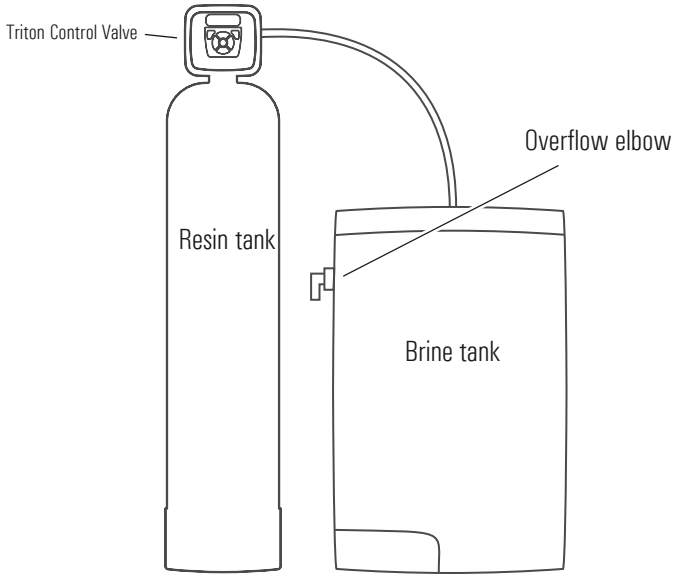

PRODUCT DESCRIPTION	PART NUMBER
Resin Tank 10" x 54"	09-03-1054BLK-XE
Resin Tank 12" x 52"	09-03-1252BLK-XE
Resin Tank 13" x 54"	09-03-1354BLK-XE
Brine Tank Assembled 18" x 33"	09-04-1833BKNG-SIL
Brine Tank Assembled 18" x 40"	09-04-1840BKNG-SIL
Brine Well Assembly (for 18x33)	09-04-245
Brine Overflow Elbow	07-05-004
Triton Control Valve	13-V1TXUMC

# PLUMBING CONNECTION

## Typical plumbing installation



Check local codes for minimum run between Reionator Pro unit and water heater

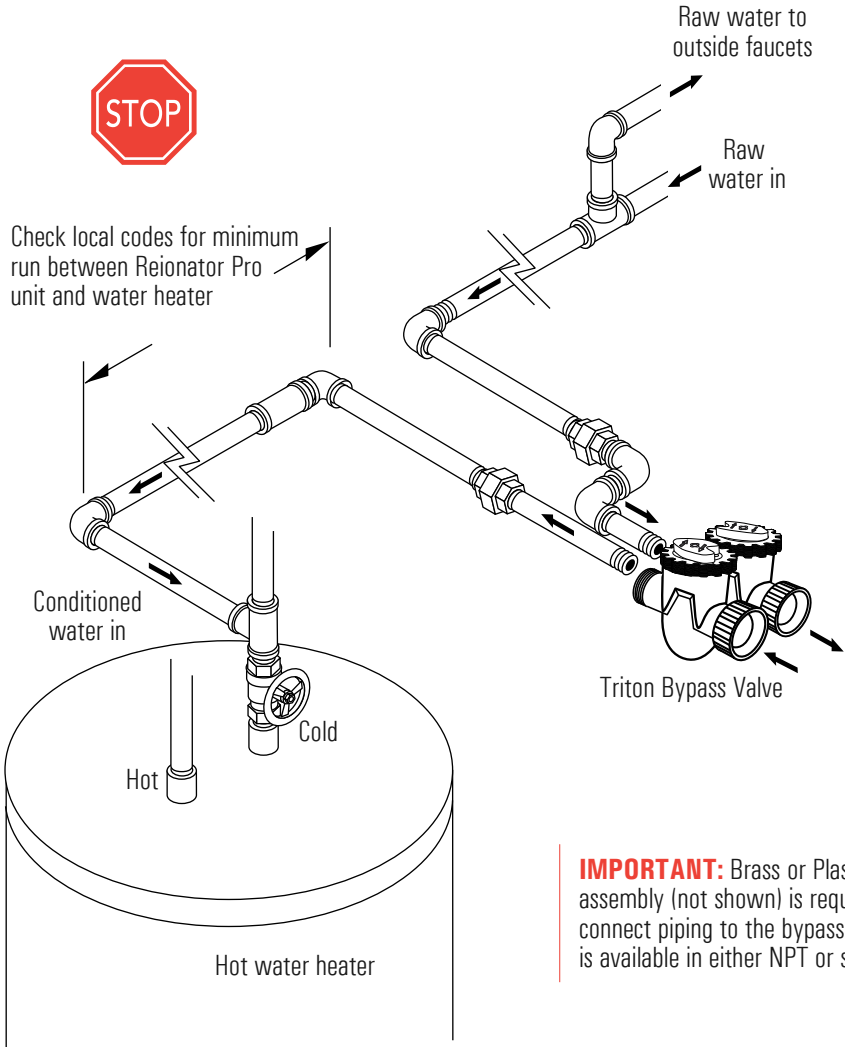

**IMPORTANT:** Brass or Plastic yoke assembly (not shown) is required to connect piping to the bypass valve and is available in either NPT or solvent.

# DRAIN LINE CONNECTION

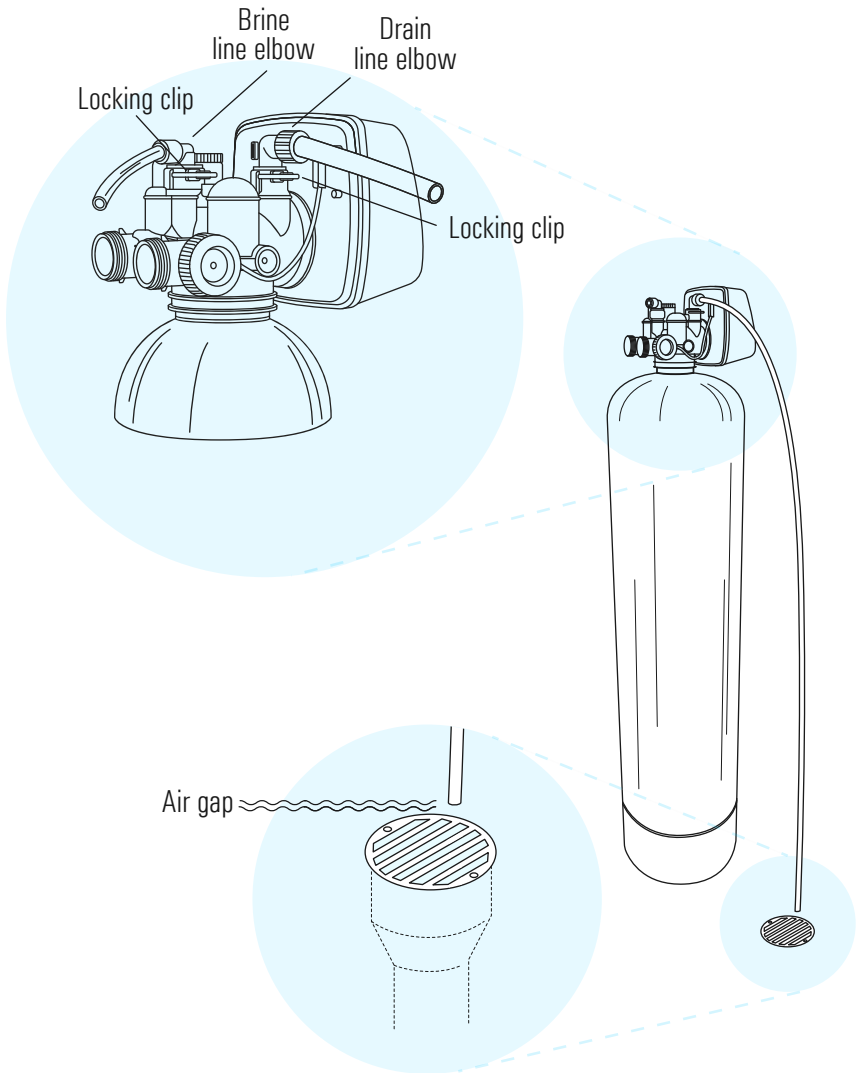

**CAUTION:** Never connect drain line directly into drain, sewer line or trap. Always allow an air gap of at least 25mm (1 inch) or 2 pipe diameters between the drain line and waste water to prevent the possibility of sewage being back siphoned.

# STARTING UP THE SYSTEM

## Flushing, Conditioning and Sanitizing



Did you connect the drain line securely to the valve?  
Did you connect the brine line securely to the valve?

**Step 1.** Make sure the system is in the “Bypass” position before turning the main water back on. See page 11. Make sure the drain line provided is connected securely to the control valve and is properly located over a drain. It is recommended that a separate drain line, not provided, is connected to the overflow elbow on the brine tank and is properly located over a drain. Make sure the brine line is connected to both the air check in the brine well and the control valve. Make sure the control valve is plugged into an operating outlet with the correct voltage and is properly grounded.

**Step 2.** Press and Hold the REGEN button on the Triton valve until you hear the motor engage. This will initiate an immediate manual regeneration of the system. Turn the bypass valve to Diagnostic Mode (figure 3 on page 11). The screen will indicate “FILL”. You should hear water entering the system, fill the mineral tank and then begin filling the brine tank. Wait a few minutes to ensure the control valve pushes water to brine tank. You should see the water level in the brine tank increasing as the system puts water in brine tank to make brine. If everything is working, and you have verified that water in brine tank is rising, press and release the REGEN button. You will hear the motor engage and move the piston into the “SOFTENING” position. Check all connections to make sure the system has no leaks. To advance to the next stage of regeneration, press and release the REGEN button. You will hear the motor engage and move the piston into the “DRAW” position. You should see the water level in the brine tank decreasing as the system draws water from brine tank to regenerate the mineral tank. If everything is working, and you have verified that water in brine tank is dropping, press and release the REGEN button. Check all connections to make sure the system has no leaks. You will hear the motor engage and move the piston into the “BACKWASH” position. You should see and hear water going through the drain line to the drain. Allow the system to backwash until the water going to drain is clear. If everything is working, and you have verified that water is going to drain via drain line, press and release the REGEN button. Check all connections to make sure the system has no leaks. You will hear the motor engage and move the piston into the “RINSE” position. You should see and hear water going through the drain line to the drain. If everything is working, and you have verified that water is going to drain via drain line, press and release the REGEN button.



# STARTING UP THE SYSTEM

Check all connections to make sure the system has no leaks. Once you've verified all stages of regeneration are working appropriately, and have verified there are no leaks, fill the brine tank with sodium chloride or potassium chloride softening pellets.

**Step 3.** To ensure sanitary conditions in the mineral and brine tanks, place 1.5 ounces of common household bleach into the brine tank. Press and hold the REGEN button for 3 seconds to move the control valve into regeneration sequence. Allow the FILL cycle to complete (5-8 min). Then press the REGEN button to allow the motor to move to the "SOFTENING" position and then push REGEN again, moving system to "DRAW" position. This cycle normally takes about 60 minutes; however, 15 minutes should be sufficient to pull the chlorine from the brine tank. After 15 minutes, press and hold the REGEN button to move the control valve to the "BACKWASH" position. Let the valve complete this cycle, and also the "RINSE" cycle, which will come next. Once the valve has completed the "RINSE" cycle, it will automatically return to "SOFTENING". In step 5, you will set the valve to "Regen Today" so that it will regen the night after install at the specified time. If there is any residual chlorine, it will be removed during that regeneration.

**Step 4.** Make sure that the bypass valve is completely set in the "Normal Operation" position. Let the water in the taps of the building run for several minutes to purge the unconditioned water out of the pipes. After several minutes, take a water sample and test for hardness from the running tap. If a hardness test reads "soft" water, the installation is correct.

**Step 5.** Press and release the REGEN button. You should see "Regen Today" appear on the LCD screen. This will instruct the control valve to regenerate tonight at the specified time (usually 2:00 am).

**Step 6.** Drain hot water heater and let it refill with conditioned water. We suggest draining the hot water by turning on the hot water taps in the house. We recommend doing this just prior to bedtime.

# DISPLAYS & PROGRAMMING

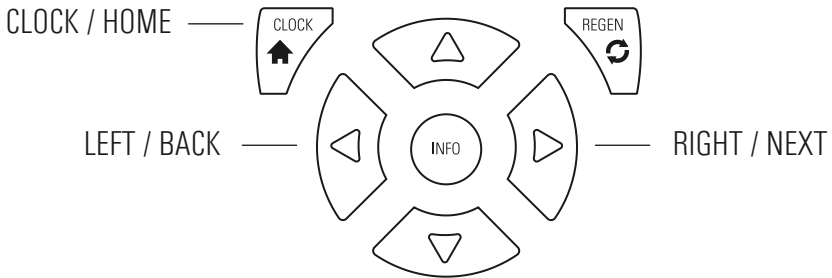

## SET CLOCK

- Press CLOCK one time.
- The hours will begin to flash.
- Use  $\triangle$  or  $\nabla$  to adjust the hour. The hours will cycle through AM and PM.
- Once the hour is set correctly, press  $\triangleright$  one time to set the minutes.
- Once you see the minutes flashing, use  $\triangle$  or  $\nabla$  to adjust the minutes.
- Once time is set, press CLOCK.

## SETTING HARDNESS

- Enter the Installer Screens by pressing and holding  $\triangleright$  +  $\triangle$  simultaneously for 3-5 seconds.
- Once the display changes, if the system is programmed to calculate grains of hardness, the first display in the installer screens will be "Water Hardness".
- Use  $\triangle$  or  $\nabla$  to increase or decrease the hardness level based on the customers raw water total hardness.
- Once the hardness level is set, you can advance to the next Installer Screen by pressing  $\triangleright$  OR you can return to the home display by pressing  $\text{house icon}$

# DISPLAYS & PROGRAMMING

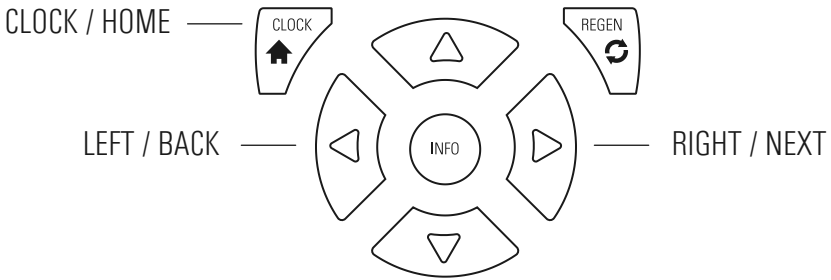

## SETTING REGENERATION TIME

- Enter the Installer Screens by pressing and holding  $\triangleright + \triangle$  simultaneously for 3-5 seconds.
- Once the display changes, press  $\triangleright$  until you reach the "Regeneration Time" display.
- When on the "Regeneration Time" display, use  $\triangle$  or  $\nabla$  to adjust the hour. The hours will cycle through AM and PM.
- Press  $\triangleright$  to move the cursor to adjust the minutes. Use  $\triangle$  or  $\nabla$  to adjust the minutes.
- Advance to the next Installer Screen by pressing  $\triangleright$  OR you can return to the home display by pressing  $\uparrow$

**Error**

## ERROR MESSAGE

- SOFT RESET (to reset "ERROR" code)  
Press and hold  $\triangleright + \text{REGEN}$  simultaneously for 3-5 seconds until valve resets.
- If the word "ERROR" persists, after a soft reset, and a number is alternately flashing on the display, contact an authorized WaterTech dealer for service help. This indicates that the valve was not able to function properly. This is a rarely encountered malfunction.

# BYPASS VALVE OPERATION

The bypass valve is typically used to isolate the control valve from the plumbing system's water pressure in order to perform control valve repairs or maintenance. The 1" full flow bypass valve incorporates four positions including a diagnostic position that allows service personnel to work on a pressurized system while still providing untreated bypass water to the facility or residence. Its completely non-metallic, all plastic design allows for easy access and serviceability without the need for tools.

The bypass body and rotors are glass-filled Noryl and the nuts and caps are glass-filled polypropylene. All seals are self-lubricating EPDM to help prevent valve seizing after long periods of non-use. Internal o-rings can easily be replaced if service is required. The bypass consists of two interchangeable plug valves that are operated independently by red arrow-shaped handles. The handles identify the flow direction of the water. The plug valves enable the bypass valve to operate in four positions.

**Refer to corresponding Bypass Valve Instructions on the following page.**

**Figure 1.** Normal Operation Position: The inlet and outlet handles point in the direction of flow indicated by the engraved arrows on the control valve. Water flows through the control valve during normal operation and this position also allows the control valve to isolate the media bed during the regeneration cycle.

**Figure 2.** Bypass Position: The inlet and outlet handles point to the center of the bypass, the control valve is isolated from the water pressure contained in the plumbing system. Untreated water is supplied to the plumbing system.

**Figure 3.** Diagnostic Position: The inlet handle points in the direction of flow and the outlet handle points to the center of bypass valve, system water pressure is allowed to the control valve and the plumbing system while not allowing water to exit from the control valve to the plumbing.

**Figure 4.** Shut Off Position: The inlet handle points to the center of the bypass valve and the outlet handle points in the direction of flow, the water is shut off to the plumbing system. If water is available, on the outlet side of the softener, it is an indication of water bypassing the system (i.e. a plumbing connection somewhere in the building bypasses the system).

# ***BYPASS VALVE ILLUSTRATIONS***

**FIGURE 1.  
NORMAL OPERATION**

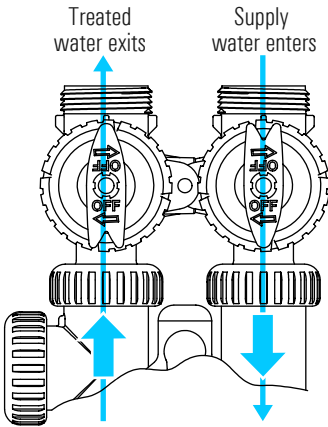

**FIGURE 2.  
BYPASS OPERATION**

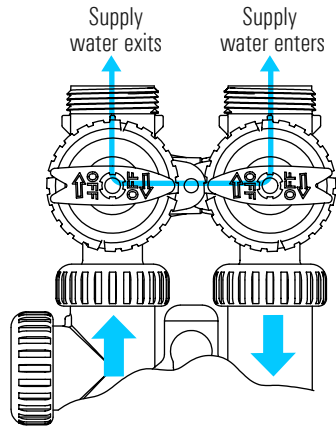

**FIGURE 3.  
DIAGNOSTIC MODE**

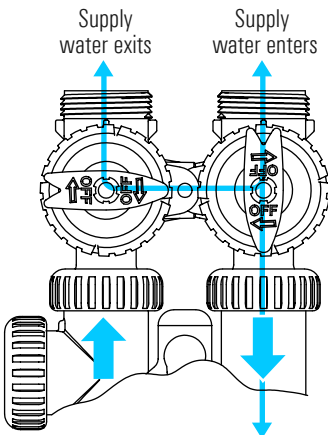

**FIGURE 4.  
SHUT OFF MODE POSITION**

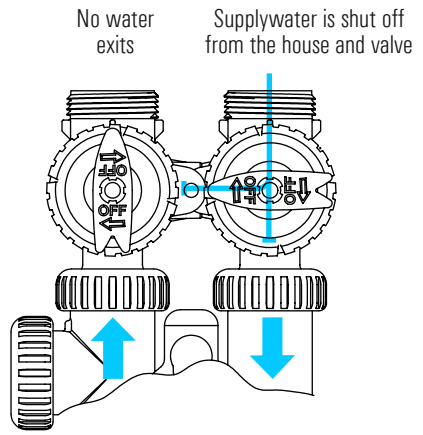

# SPECIFICATIONS

WaterTech recommends the use of Potassium Chloride (KCl) as a regenerant salt.

Model <sup>1</sup>	* <sup>1</sup> Softening Efficiency @ Stated Salt Setting (Grains Per Pound)	<sup>2</sup> Softening Capacity @ Stated Salt Setting (Grains Per Gallon)	Max. Recommended Hardness (Grains Per Gallon)	Tank Sizes
RX10	3998 @ 4.7 lbs.	18,901 @ 4.7 lbs.	45	10" X 54"
RX12	3998 @ 6.4 lbs.	25,443 @ 6.4 lbs.	55	12" X 52"
RX13	3998 @ 7.8 lbs.	31,259 @ 7.8 lbs.	65	13" X 54"

\* The efficiency is only valid at the stated salt dosage and maximum service flow.

<sup>1</sup> Softening efficiency values based on NaCl as the regenerant salt.

<sup>2</sup> Softening capacity values based on NaCl as the regenerant salt.

Model <sup>1</sup>	Max. Recommended Flow Rate / Service Flow Rate (Gallons per minute)	Max. Flow to Drain During Regeneration (Gallons per minute)	@PSID	Total Bed Depth (FT3)
RX10	11.0	1.7	9	1.417
RX12	15.8	2.7	13	1.910
RX13	17.5	3.2	15	2.350

Efficiency rated softeners shall have a rated salt efficiency of not less than 3350 grains of total hardness exchange per pound of salt, and shall not deliver more than its listed rating.

MIN/MAX WORKING PRESSURE: 20-150 psi or 138-861 kPa

MIN/MAX OPERATING TEMPERATURE: 40°F-110°F or 4.4-43.3° C

MAX FLOW TO DRAIN DURING REGENERATION: 3.2 gpm or 12.1 l/min

INPUT VOLTAGE: 110-120VAC @ 60Hz

OPERATING VOLTAGE: 12VAC @ 60Hz









# WaterTech Industries Residential

# REIONATOR<sup>®</sup> PRO

## LIMITED LIFETIME WARRANTY

Applicable to REIONATOR PRO<sup>®</sup> Models: Pro Series: RX10, RX12, RX13, RXF10

Water Tech Industries (WTI) hereby warrants said equipment, **only to the original purchaser at the original installation location.**

**THIS WARRANTY PERIOD BEGINS** at the time of initial installation and use. The warranty becomes **valid upon registration of the equipment.**

**GENERAL PARAMETERS** — This warranty applies only to systems installed on **USA OR CANADIAN residential, municipal (city water) water supplies** that meet US Environmental Protection Agency MCL standards (or similar). REIONATOR PRO<sup>®</sup> products installed outside these parameters, will have the Standard Product Warranty rather than the Limited Lifetime Warranty applied – see website [watertech.com](http://watertech.com) for details.

**LIMITED LIFETIME WARRANTY ON CONDITIONER AND BRINE TANK** — Water Tech Industries will replace or repair (at WTI option) any conditioner tank OR brine tank that becomes unusable because of leakage, corrosion or rupture due to manufacturers defect . All internal mechanical components are warranted for a **period of five (5) years** from date of installation.

**LIMITED LIFETIME WARRANTY ON RESIN** — The REIONATOR PRO<sup>®</sup> has been equipped with the highest quality water treatment media (certified to NSF Standards). If, upon factory inspection, the resin is found to be defective, Water Tech Industries will furnish replacement resin. The resin warranty does not cover resins subjected to water containing greater than 3.0-ppm of free chlorine or chloramines or containing greater than 1.0-ppm total Iron and/or Manganese. Resin which has been fouled by iron, manganese, organics (or other contaminants not designed for treatment by the REIONATOR PRO<sup>®</sup>) is not covered.

**LIMITED LIFETIME WARRANTY ON CONTROL VALVE** — The REIONATOR PRO<sup>®</sup> has been equipped with the highest quality water conditioning control valve available. If, upon factory inspection, the control valve body or PC board is found to be defective, Water Tech Industries will furnish repair or replacement (at WTI option) of the control valve body and/or the PC board. All internal mechanical components are warranted from manufacturers defect for a period of five (5) years from the date of installation.

**EXCLUSIONS AND LIMITATION OF LIABILITY** — Water Tech Industries' liability for special, incidental, or consequential damages is expressly disclaimed. In no event shall Water Tech Industries' liability exceed the obligation of repairing or replacing any part that becomes defective under valid warranty coverage as described above. Cosmetic damage that does not affect the process functionality of the equipment is not covered. Water Tech Industries makes every effort to ensure that all illustrations and specifications are correct. However, these do not imply a warranty that the product is

merchantable or fit for a particular purpose, or that the product may not vary from the illustrations and specifications.

The warranty contained herein is in lieu of all other warranties, expressed or inferred, including any implied warranty of fitness for a particular purpose. Labor and transportation costs incidental to the delivery or replacement of parts other than WTI factory repairs are not covered under this warranty. In the event of a warranty replacement or repair, WTI will cover the cost of shipping the covered components. This warranty expressly excludes any system which has been damaged by accident, fire, flood, Act of God, abuse, neglect, freezing, excessive temperature (below 40° F or above 110° F.), inappropriate pressure (below 20 psi or above 100 psi), misuse, alteration of product in any way by owner or installing company, product identification tampering, misapplication, installation or operation not consistent with WTI instructions and installation outside of applicable plumbing codes and local regulations. Furthermore, this warranty expressly excludes any system which has been out of service for more than 90 days continuously. Fulfillment of the warranty coverage by WTI is contingent on proper execution of the procedures set forth in the WTI Warranty RGA policy. No person or representative is authorized to assume for Water Tech Industries any liability on its behalf, or in its name, except to refer the purchaser to this warranty. This warranty gives you specific legal rights, you may also have other rights which vary from state to state.

**WHAT MUST YOU DO TO OBTAIN WARRANTY SERVICE – The warranty registration (via phone or website) must be completed within ninety (90) days of installation to validate the REIONATOR PRO® Limited Lifetime Warranty.** Units that have not been registered will be covered under the Standard 5/10 Year Product Warranty rather than the Limited Lifetime Warranty. Repair work **MUST** be performed by an authorized Water Tech Dealer. In the event that authorized dealer service is not available, defective components may be returned directly to Water Tech Industries with prior approval for warranty service. The registered owner must contact Water Tech for return instructions and return the defective component, freight prepaid, with proof-of-purchase, within the applicable warranty period.

Reionator Pro Warranty 17-01-025

***PRODUCT MUST BE REGISTERED TO ACTIVATE WARRANTY  
VISIT [WWW.WATERTECH.COM](http://WWW.WATERTECH.COM) OR CALL 469-521-1180***

